

Standardowe łańcuchy pociągowe typ M
Conveyor standard chains type M
PN-71/M-84186, DIN 8167
Z rolką wysoką z obrzeżem typu F
With flanged roller type F

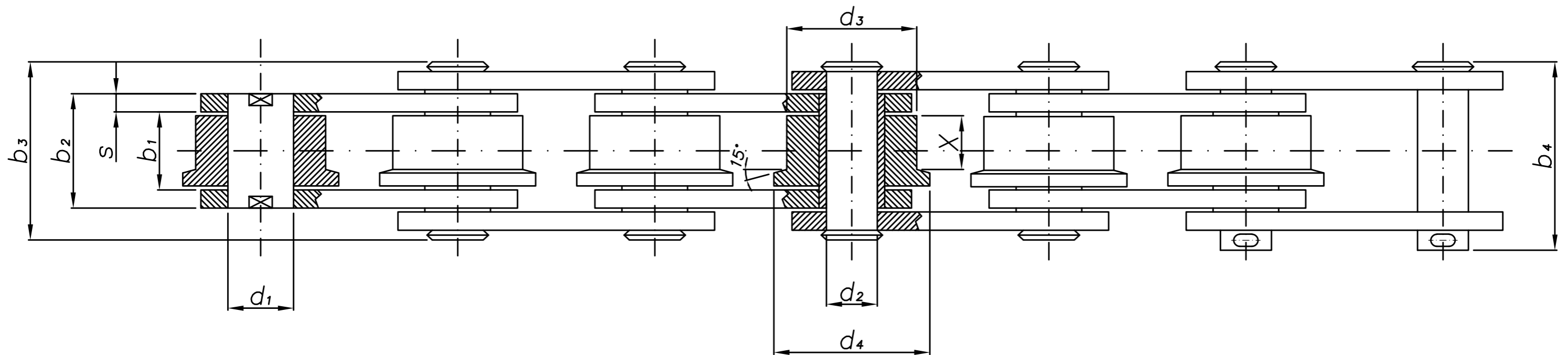
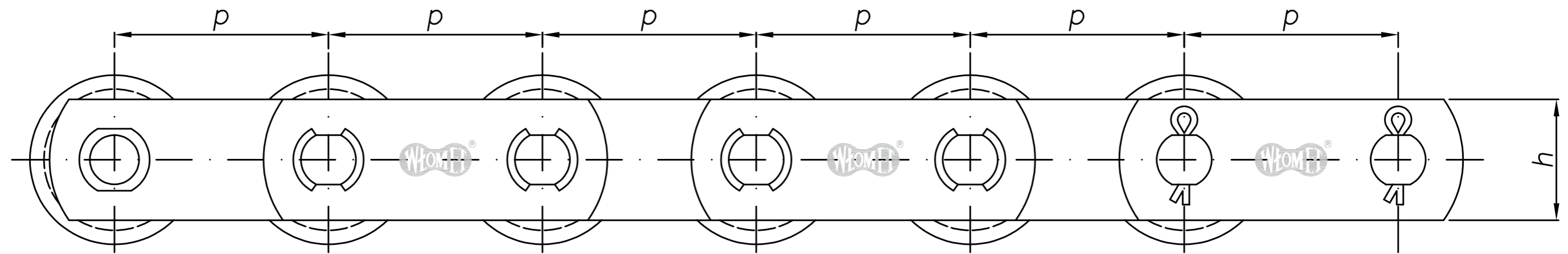

Standardowe łańcuchy pociągowe typ M

Conveyor standard chains type M

PN-71/M -84186, DIN 8167

Z rolką wysoką z obrzeżem typu F

With flanged roller type F

	p							b ₁ min	b ₂ max	b ₃ max	b ₄ max	d ₁ max	d ₂ max	d ₃ max	d ₄ max	X	s min	h max	F min
	mm							mm	mm	mm	mm	mm	mm	mm	mm	mm	mm	mm	mm
1	2							3	4	5	6	7	8	9	10	11	12	13	14
M 20	40	50	63	80	100	125	160	16,00	22,00	33,00	37,00	9,00	6,00	25,00	30,00	11,50	3,00	18,00	20,00
M 28	50	63	80	100	125	160	200	18,00	25,00	36,00	40,00	10,00	7,00	30,00	36,00	13,00	3,00	20,00	28,00
M 40	63	80	100	125	160	200	250	20,00	28,00	41,00	45,00	12,50	8,50	36,00	42,00	14,00	4,00	25,00	40,00
M 56	63	80	100	125	160	200	250	24,00	33,00	48,00	54,00	15,00	10,00	42,00	50,00	17,50	4,00	30,00	56,00
M 80	80	100	125	160	200	250	315	28,00	39,00	55,00	64,00	18,00	12,00	50,00	60,00	20,50	5,00	35,00	80,00
M 112	80	100	125	160	200	250	315	32,00	45,00	65,00	73,00	21,00	15,00	60,00	70,00	23,00	6,00	40,00	112,00
M 160	100	125	160	200	250	315	400	37,00	53,00	78,00	85,00	25,00	18,00	70,00	85,00	26,50	8,00	50,00	160,00
M 224	125	160	200	250	315	400	-	43,00	60,00	85,00	97,00	30,00	21,00	85,00	100,00	31,00	8,00	60,00	224,00
M 315	160	200	250	315	400	-	-	48,00	70,00	100,00	114,00	36,00	25,00	100,00	120,00	34,00	10,00	70,00	315,00
M 450	200	250	315	400	-	-	-	56,00	82,00	114,00	130,00	42,00	30,00	120,00	140,00	41,00	12,00	80,00	450,00

F – obciążenie zrywające (min.)

Q – masa 1 mb łańcucha

Łańcuch może być nitowany na stałe lub rozbierny.

F – breaking load (min.)

Q – weight kg/m

The chain can be permanently riveted or demountable.

Orientacyjne masy łańcuchów pociągowych tulejkowych – kg/mb.

Podziałka mm											
	40	50	63	80	100	125	160	200	250	315	400
M 20	2,85	2,40	2,15	1,80	1,60	1,40	1,25	-	-	-	-
M 28	-	3,55	3,00	2,60	2,30	2,00	1,75	1,60	-	-	-
M 40	-	-	4,70	4,00	3,50	3,10	2,75	2,45	2,25	-	-
M 56	-	-	7,30	6,20	5,40	4,70	4,10	3,65	3,30	-	-
M 80	-	-	-	10,00	8,50	7,40	6,40	5,70	5,10	4,60	-
M 112	-	-	-	15,35	13,10	11,25	9,60	8,40	7,50	6,70	6,10
M 160	-	-	-	-	20,50	17,50	15,00	13,10	11,50	10,40	9,30
M 224	-	-	-	-	-	28,10	23,50	20,50	17,80	15,70	14,00
M 315	-	-	-	-	-	-	36,15	31,10	27,15	23,80	21,20
M 450	-	-	-	-	-	-	-	48,00	41,50	36,00	31,50